

Component Tracking: Pressure Relief Valve component

Phase

Payload to Railinc

PRV Manufacturer (C4)

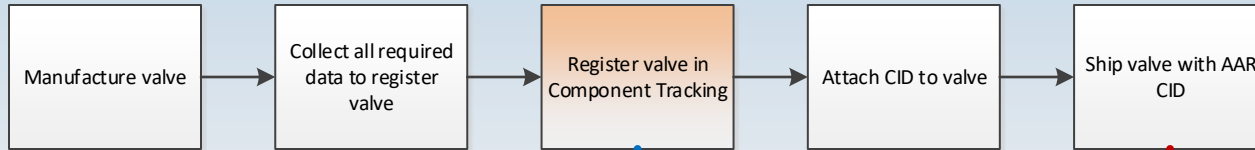

AAR QA Code	8NYB1000000001
Model No	123456
Pressure	165 Lbs
Date Tested	01/19/2014
Condition	New
Serial Number	A00005

PRV Installer (C6)

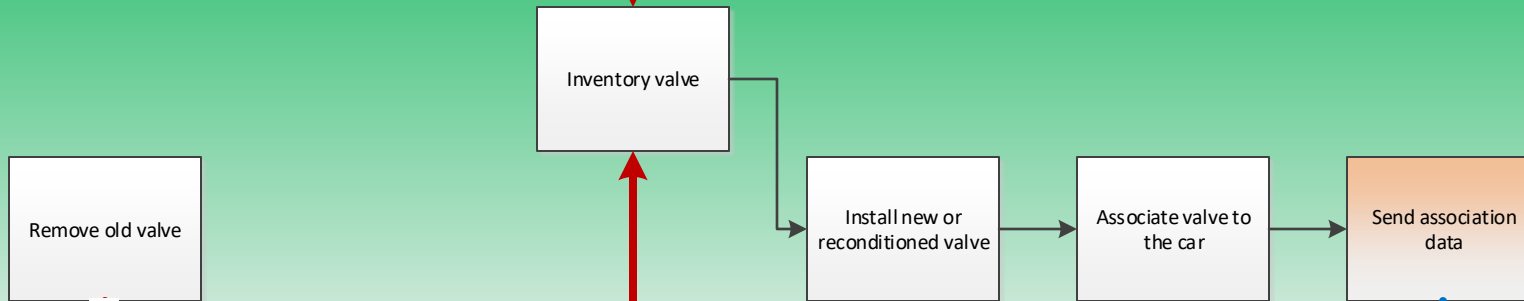

Component ID	8NYB1000000001
Equipment ID	RAIL 652563
Association Date	01/24/2014
SPLC	123456
Performer	RAIL
Reporter	RAIL

PRV Reconditioner (C5)

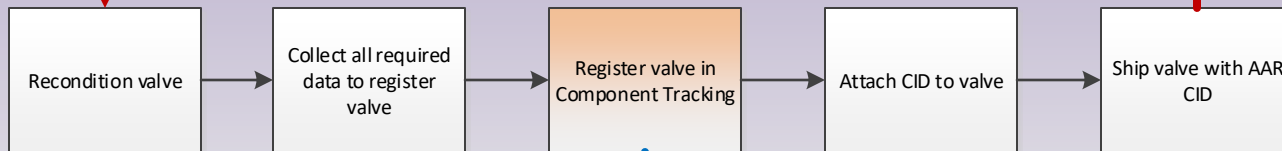

AAR QA Code	8NYB1000000001
Model No	123456
Pressure	165 Lbs
Date Tested	01/19/2014
Condition	New
Serial Number	A00005

Railinc

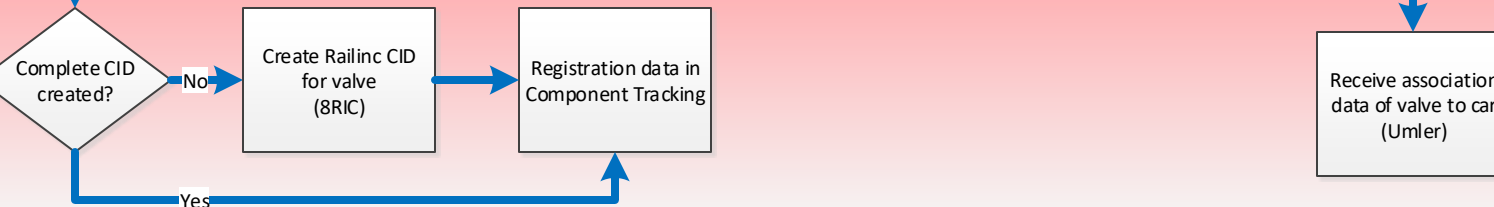

Receive association data of valve to car (Umler)